

Image Analysis Based Open Source Conveyor Belt Prototype for Wood Pellet and Chip Quality Assessment

F. Pallottino¹, P. Menesatti¹, F. Antonucci¹, S. Figorilli¹,
A. R. Proto² and C. Costa^{1*}

¹ Consiglio per la ricerca in agricoltura e l'analisi dell'economia agraria (CREA)
Unità per l'ingegneria agraria. Via della Pascolare 16
00015 Monterotondo scalo (Rome), Italy
*Corresponding author

² Mediterranea University of Reggio Calabria, Department of Agriculture
Feo di Vito, 89122 – Reggio Calabria, Italy

Copyright © 2016 F. Pallottino et al. This article is distributed under the Creative Commons Attribution License which permits unrestricted use distribution and reproduction in any medium, provided the original work is properly cited.

Abstract

Pellet represent a well spread commodity for energy production in Europe with a rapidly increasing market. Previous studies evidenced as the color could be used for visual prediction of pellets quality through RGB calibration methodologies paired with image analysis techniques. The open source software and hardware available nowadays represent a great possibility for prototypes development due to their affordable nature and commercially suitable license. Therefore, this work point to the development of an image analysis based open source conveyor belt prototype for pellet quality assessment. The realized open source system, coupled with image analysis, could allow a rapid characterization of wood pellet and chip. Moreover, being based on open source technologies, it resulted to be low cost and could be able to characterize large quantities of products. The system, following a proper calibration, may be used in future for products quality labelling and certifications.

Keywords: Wood pellet; Wood chip; Image analysis; Quality assessment; Arduino

Introduction

Among all wood pellet is one of the wider internationally spread commodities for energy production and its market is rapidly increasing in Europe [1, 14, 15] mainly driven by the fairly low cost per energy unit and the European and National subsidy systems to achieve the 2020 targets. At the moment the continuous increasing demand for wood pellets seems not to be totally satisfied by the domestic production, not for technological reasons, but for shortage in primary resources and for the competition with large power plants [2] and wood industry. Even if there are not precise statistics for the sector, the European market appear dependent upon importation [3] and the ENplus annual report highlights that the Italian import of wood pellets from abroad (within EU-27, Canada, United States, South America and New Zealand) is actually filling the gap between the domestic production and consumption [4]. Pellets have higher energy density, when compared with other biofuels, resulting in lower transportation and storage costs [5, 6] and moreover present a regular shape that allows the automation of feeding procedure for burning [7].

However not all pellets do present the same quality which is expression of different parameters depending on both, intrinsic feedstock characteristics and treatment or production conditions. The properties owing to the raw materials affect pellets quality because their constituents are found practically unchanged in the final product. Indeed, tree species as well as wood provenance and quality certification have been found to influence the pelletizing process [8, 9], and the final pellet quality [10, 11, 16]. Sgarbossa et al. [12] evidenced as the color could be used for visual prediction of pellets quality. The applicability of such method for the evaluation of pellets quality is based on RGB calibration methodologies paired with image analysis techniques, resulted to be an affordable and useful tool.

Open source software and hardware available nowadays represent a great possibility for prototypes development due to the thick coding community and the possibility to use such technologies even at commercial level.

Therefore, based on such evidences the present work point to the development of an image analysis based open source conveyor belt prototype for pellet quality assessment. Wood pellets and wood chips tested were produced in the Italian Calabria region (Southern Italy).

Materials and methods

The open source prototyped (Fig. 1) was composed pairing together a conveyor belt, an optoelectronic system and a feeding separator. The optoelectronic system, positioned vertically with respect to the belt plane, uses a GigE Vision Camera Mako G-125C PoE equipped whit a CCD sensor Sony ICX445 of 1.2 MP (1292 x 964 pixels) acquiring consequent images of the objects. The camera was boxed with wood panels in order to control the light during the acquisition.

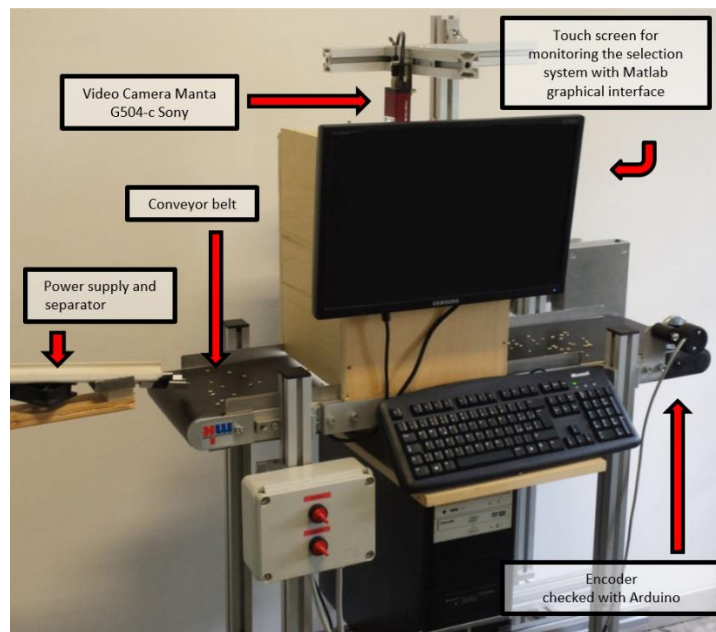

Figure 1 - Prototype composed by: a conveyor belt equipped with a separator (feeding system), an optoelectronic system that uses a GigE Vision Camera Manta G-504B/C and a pc with touch screen for ease of use.

The lighting system was built using led array and a white internal finish in order to obtain uniform light distribution. Moreover, the system has been equipped with an encoder to record the belt positioning e therefore to synchronize the image acquisition.

The system was mainly built using the open source electronic prototyping platform Arduino. In details were realized all the electronic circuits for integrating the Arduino components as following:

- Voltage regulation V_{cc} for powering the various components (valves, encoders, feeder, Arduino, acquisition room lighting);
- Relay for managing the conveyor belt;
- Regulation and control of DC motors in the feeder
- MOSFET for control of pneumatic solenoid valves.

A Arduino® has been used to manage the encoder, while another for the controlling the conveyor belt, the feeder, the room lighting and the solenoid valves. Figure 2 shows the main patterns of the system, in particular the Encoder (A), the main power supply board and control devices (B).

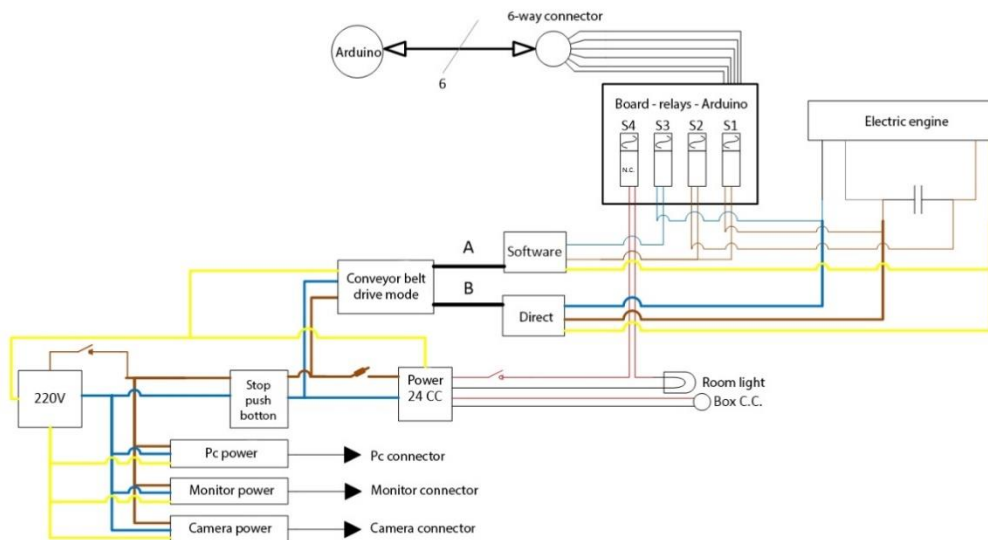

Figure 2 – General scheme of the systems patterns showing the connection among power supply with Arduino, the conveyor belt and the pc.

Software and image acquisition

The software is divided following two types of implementation. The first relates to the programming of the microcontroller MCU to the reading of the encoder, the second the development of a multithreaded software for the synchronized acquisition of the images by means of high-resolution camera Ethernet and the encoder. The microcontroller software is structured by the serial USB connection for sending impulses to the main software, and the control logic for processing the encoder signals. The generated pulses are processed to identify the correct sequence that determines the direction of continuous rotation and the presence of eventual errors due to interference and / or electrical malfunctioning.

Processing of pulses is done through the implementation of the “gray code” that makes the adjustments (forward - stop - backward) easier and less error-prone. The main software plays a key role as it manages the image acquisition and the synchronization with the encoder. The synchronism is made possible through the use of multithread, in particular two parallel threads are started, the first is responsible for receiving the number of encoder pulses, the second to acquire the images.

The development environment used is C / C ++ for the software and MCU programming, while the main software has been developed in Java.

Once the system has been synchronized, following the software development, in order to test the prototype efficiency were automatically acquired some images (Figure 3) of wood pellets and wood chips produced in the Italian Calabria region (Southern Italy). Samples of 200 g each of wood pellet from alder, poplar and chestnut and alder wood chip were analyzed.



Figure 3 – Samples of the images acquire. On the left side wood pellet, on the right side wood chips coming from the Italian region Calabria.

Results & discussion

In order to calculate the exact belt operating parameters, and thus setup exactly the frame rate to correctly acquire images, to minimize the errors, time, lengths and pulses frequency were all assessed on the base of ten full rounds of the encoder wheel.

Table 1 – Conveyor belt operating parameters

Encoder wheel circumference (mm)	200
Encoder wheel full rounds used for calculations	10
Belt speed (mm/s)	10.811
Belt speed (m/min)	0.649
Round / minute (rpm)	3.243
Time / round (s)	18.5
Encoder pulse / round (Hz)	1000
Pulses / s (Hz)	54.054
Time / pulse (s)	0.019
Pulses / mm	5

As shown in Table 1 the belt speed recoded was equal to 10.8 mm/s. At such a speed the encoder wheel, with a circumference equal to 200 mm, was able to complete 3.243 rounds per minute. Knowing a priori the number of encoder pulses per round was possible to calculate the pulses per s (54.054 Hz), the time needed for one pulse (0.019 s) and the number of pulses per mm of belt (5).

Table 2 – Operative camera acquisition parameters.

Distance from lens to plane – lens bottom to the belt plane (mm)	250
Width resolution (y - columns)	1292
Height resolution (x - lines)	964
Y FOV (Field Of View, mm)	118
X FOV (Field Of View, mm)	158
Encoder pulses / Y FOV	590

Table 2 report the data regarding the Mako camera resolution (width and height resolutions) and the distance between the camera lens and the belt plane used for the image acquisition (250mm). Measuring the Y and the X FOV (Field Of Views) was possible to calculate the encoder pulses needed to cover entirely the Y FOV and thus triggering correctly the acquisition of each image without overlapping.

The synchronized images were acquired by the prototype imaging sensor and elaborated obtaining Calabrian wood pellet and chip color, shape and other dimensional aspects (data not shown) using the methods proposed by Febbi et al. [13] and Sgarbossa et al. [12]. These data could help: *i.* quality managers of large biofuel suppliers or purchasers, *ii.* chipper machine constructors to verify the prototype performances depending from different settings (knives position and number, cutting and feeding speeds, cutting and sharpness angles, anvil height, cutting direction, etc.) in a given experimental situation, and *iii.* engineering machine certification in order to fix standard methodologies highly replicable.

Conclusions

The proposed open source conveyor belt prototype coupled with image analysis based methods could allow a rapid characterization of wood pellet and chip. The prototype is low cost, being based on open source technologies, and could characterize large quantities (the whole lot) or when frequent sampling is required (*e.g.*, for an internal quality system). More samples or large amounts would reduce the uncertainty arising from sampling and potentially could increase the quality and value of wood pellet and chips.

Acknowledgements. This study were funded by Project “ALForLab”(PON03PE_00024_1) co-funded by the National Operational Programme for Research and Competitiveness (PON R&C) 2007-2013, through the European Regional Development Fund (ERDF) and national resource (Revolving Fund -Cohesion Action Plan (CAP) MIUR)

References

- [1] R. Sikkema R, M. Steiner, M. Junginger, W. Hiegl, M.T. Hansen, A. Faaij, The European wood pellet markets: current status and prospects for 2020, *Biofuels, Bioprod Biorefining*, **5** (2011), 250-278.
<http://dx.doi.org/10.1002/bbb.277>
- [2] E. Monteiro, V. Mantha, A. Rouboa, Portuguese pellets market: Analysis of the production and utilization constrains, *Energy Policy*, **42** (2012), 129-135.
<http://dx.doi.org/10.1016/j.enpol.2011.11.056>
- [3] A. Uasuf, G. Becker, Wood pellets production costs and energy consumption under different framework conditions in Northeast Argentina, *Biomass Bioenerg*, **35** (2011), 1357-1366.
<http://dx.doi.org/10.1016/j.biombioe.2010.12.029>
- [4] N. Audigane, M. Bentele, J.M. Ferreira, A. Gyurik, J. Jossart, A.C. Mangel and N. Pieret, European Pellet Report, (2012), PellCert Project.
- [5] E. Oveisi, A. Lau, S. Sokhansanj, C.J. Lim, X. Bi, S.H. Larsson & S. Melin, Breakage behavior of wood pellets due to free fall, *Powder Technology*, **235** (2013), 493-499. <http://dx.doi.org/10.1016/j.powtec.2012.10.022>
- [6] E. Monteiro, V. Mantha, A. Rouboa, The feasibility of biomass pellets production in Portugal, *Energy Sources, Part B Econ Plan Policy*, **8** (2012), 28-34. <http://dx.doi.org/10.1080/15567249.2011.608414>
- [7] A. García-Maraver, V. Popov, M. Zamorano, A review of European standards for pellet quality, *Renewable Energy*, **36** (2011), 3537-3540.
<http://dx.doi.org/10.1016/j.renene.2011.05.013>
- [8] J. Holm, U. Henriksen, K. Wand, Experimental verification of novel pellet model using a single pelleter unit, *Energy Fuels*, **21** (2007), 2446-2449.
<http://dx.doi.org/10.1021/ef070156l>
- [9] A. Sgarbossa, C. Costa, P. Menesatti, F Antonucci, F. Pallottino, M. Zanetti, S. Grigolato & R. Cavalli, A multivariate SIMCA index as discriminant in wood pellet quality assessment, *Renewable Energy*, **76** (2015), 258-263.
<http://dx.doi.org/10.1016/j.renene.2014.11.041>
- [10] N.P.K. Nielsen, D. Gardner, T. Poulsen, C. Felby, Importance of temperature, moisture content, and species for the conversion process of wood residues into fuel pellets, *Wood Fiber Sci.*, **41** (2009), 414-425.

- [11] M.V. Gil, P. Oulego, M.D. Casal, C. Pevida, J.J. Pis, F. Rubiera, Mechanical durability and combustion characteristics of pellets from biomass blends, *Bioresource Technology*, **101** (2010), 8859-8867.
<http://dx.doi.org/10.1016/j.biortech.2010.06.062>
- [12] A. Sgarbossa, C. Costa, P. Menesatti, F. Antonucci, F. Pallottino, M. Zanetti, S. Grigolato & R. Cavalli, Colorimetric patterns of wood pellets and their relations with quality and energy parameters, *Fuel*, **137** (2014), 70-76.
<http://dx.doi.org/10.1016/j.fuel.2014.07.080>
- [13] P. Febbi, P. Menesatti, C. Costa, L. Pari & M. Cecchini, Automated determination of poplar chip size distribution based on combined image and multivariate analyses, *Biomass & Bioenergy*, **73** (2015), 1-10.
<http://dx.doi.org/10.1016/j.biombioe.2014.12.001>
- [14] D. Monarca, M. Cecchini, A. Colantoni, A. Marucci, Feasibility of the electric energy production through gasification processes of biomass: technical and economic aspects, Chapter in *Computational Science and Its Applications - ICCSA 2011*, 2011.
http://dx.doi.org/10.1007/978-3-642-21898-9_27
- [15] I. Zambon, F. Colosimo, D. Monarca, M. Cecchini, F. Gallucci, A.R. Proto, R. Lord and A. Colantoni, An Innovative Agro-Forestry Supply Chain for Residual Biomass: Physicochemical Characterisation of Biochar from Olive and Hazelnut Pellets, *Energies*, **9** (2016), no. 7, 526.
<http://dx.doi.org/10.3390/en9070526>
- [16] A. Colantoni, N. Evic, R. Lord, S. Retschitzegger, A.R. Proto, F. Gallucci, D. Monarca, Characterization of biochars produced from pyrolysis of pelletized agricultural residues, *Renewable and Sustainable Energy Reviews*, **64** (2016), 187–194. <http://dx.doi.org/10.1016/j.rser.2016.06.003>
- [17] M. Moneti, L. M. P. Delfanti, A. Marucci, R. Bedini, F. Gambella, A. R. Proto and F. Gallucci, Simulations of a plant with a fluidized bed gasifier WGS and PSA, *Contemporary Engineering Sciences*, **8** (2015), no. 31, 1461-1473. <http://dx.doi.org/10.12988/ces.2015.56191>

Received: August 1, 2016; Published: September 14, 2016